

LOGSTOR BX

Installation Instructions - Industry



Installing straight joints for SafePipe BXJoints

Application

BXJoints are used to join pipes with outer casing dimensions \varnothing 90-630 mm.

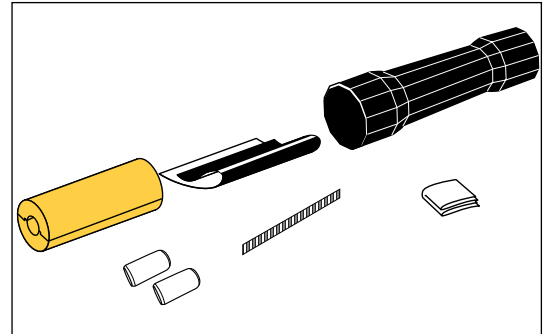

Tools

It is recommended to use the following tools when installing BXJoints:

Type:	Application:
1. Saw	Adjusting insulation shells
2. Emery cloth	Surface activation
3. Gas burner, \varnothing 50 mm	Surface activation, Shrinking film and sleeve.
4. Hammer	Installing pipe coupling
5. Spoon bit \varnothing 29 mm	Pre-drilling around perforated plastic tubes
6. Plastic tube cutter	Shortening the tracer pipe

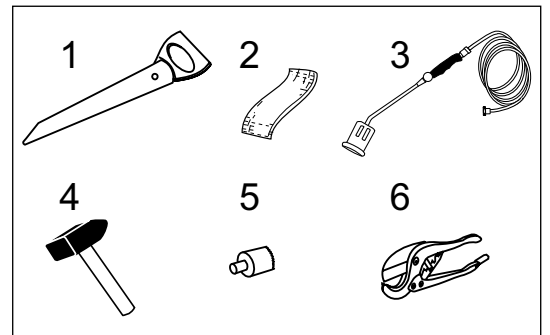

Preinstallation of casing joint

1. Place the shrink sleeve with packing on one of the pipes, before the service pipes are joined.

Notice! Align the pipes with the tracer pipe in 6 o'clock position to facilitate later installation of the tracer pipe.

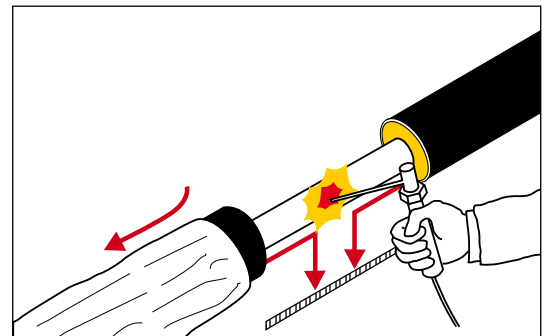

Installing straight joints for SafePipe BXJoints

Cleaning

2. Clean all surfaces in the mounting area.

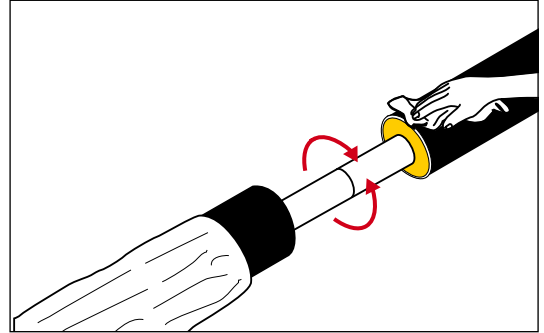

Pre-drilling

3. Before hammering the \varnothing 25 mm pipe coupling into the foam it is recommended to pre-drill around the perforated plastic tube embedded in the foam with a spoon bit.

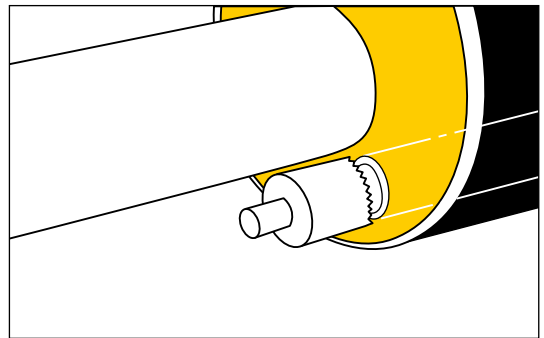

Installing the pipe coupling

4. Place the pipe coupling against the tube in the foam.

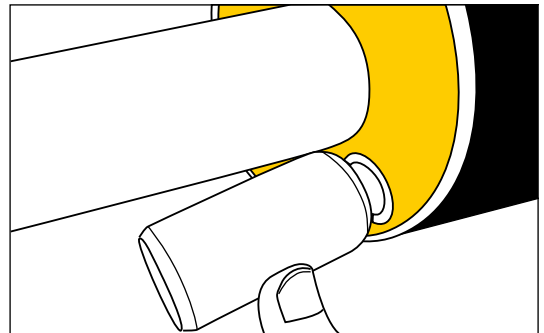

5. Hammer the coupling approx. 25-30 mm into the foam.
It is recommended to use a plastic-covered, recoilless hammer.

Repeat items 3-5 at the opposite pipe end.

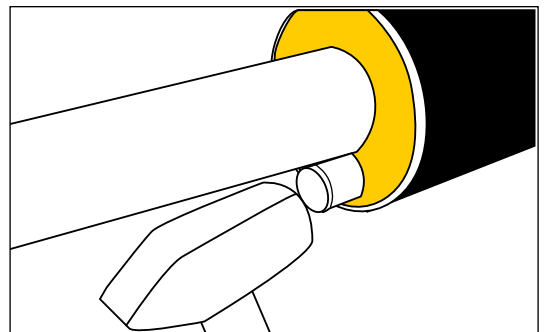

Installing straight joints for SafePipe BXJoints

Installing the tracer pipe

6. Measure the distance x and adjust the length of the tracer pipe to $x - 20$ mm.

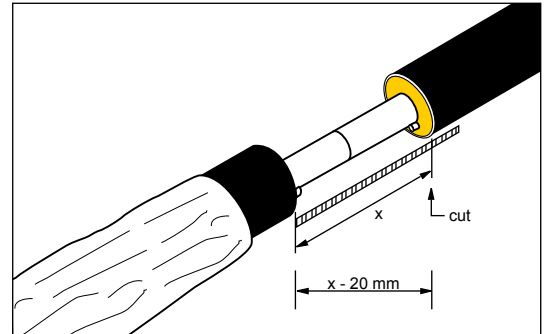

7. Pull the drag line through the tracer pipe.

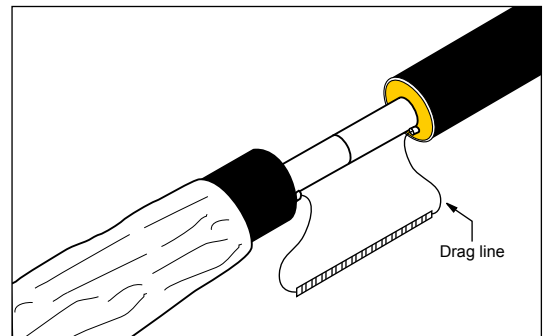

8. Insert the tracer pipe into the pipe couplings at each pipe end and secure it to the service pipe with tape.

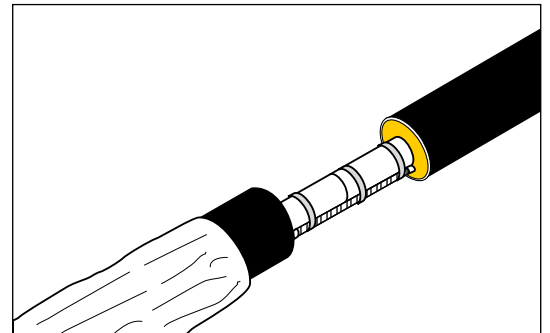

Adjusting insulation shells

9. Shorten the insulation shells to make them fit tightly between the casing pipes.

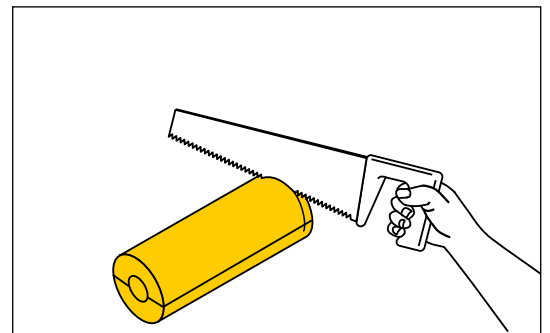

Installing straight joints for SafePipe BXJoints

Adjusting insula- tion shells, *continued*

10. Fit the insulation shells tightly between the casing pipes, using adhesive tape if required. All surfaces must be CLEAN and DRY.

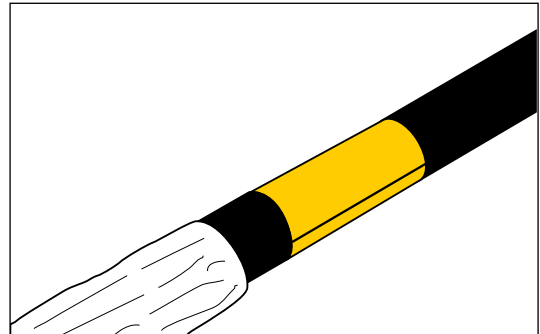

Activation

11. Activate the casing pipes with emery cloth grain size 60 at least 150 mm from both casing ends.

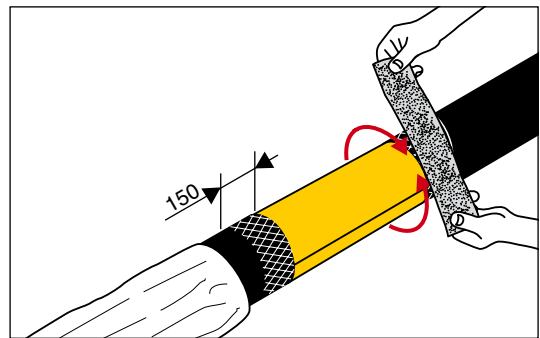

12. Activate the casing pipes with gas burner at least 150 mm from both casing ends, until the surface has a matt, silky look.

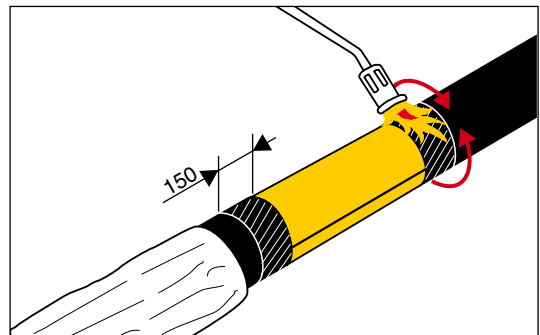

Installing shrink film

13. Place the shrink film so that the marking line forms a ring around the pipe. Attach one edge of the shrink film in the "10 o'clock" position.
14. Pull the film around the pipe by removing the adhesive paper so that the film adheres to the surface beneath it.

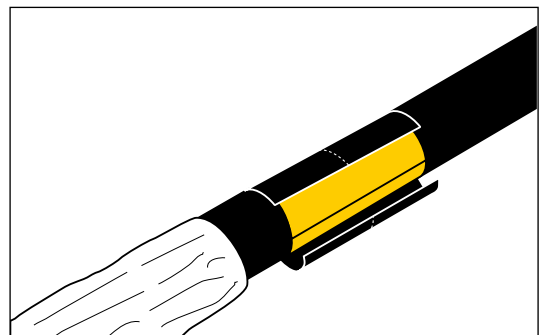

Installing straight joints for SafePipe BXJoints

Installing shrink film, continued

15. Heat the whole film from the centre towards the sides, ensuring that the mastic becomes visible at all edges and that the shrink film is tightly fitted.

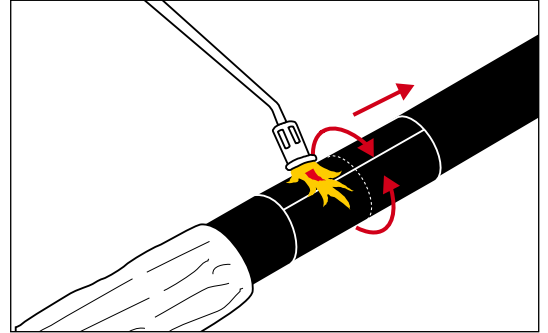

Positioning shrink sleeve

16. Remove the packing from the shrink sleeve. Check that the sleeve is CLEAN and DRY, inside and out. Remove the protective foil from the mastic.
17. Centre the shrink sleeve on the joint and mark it. Remove the mastic covering and make sure that all the foil has been removed.

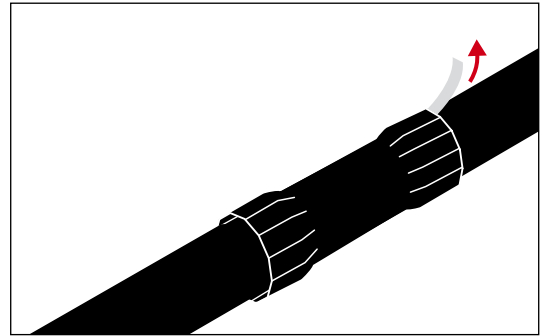

Shrinkage

18. First, shrink from the middle towards one end, then from the middle towards the other end. Avoid heating directly on the casing.

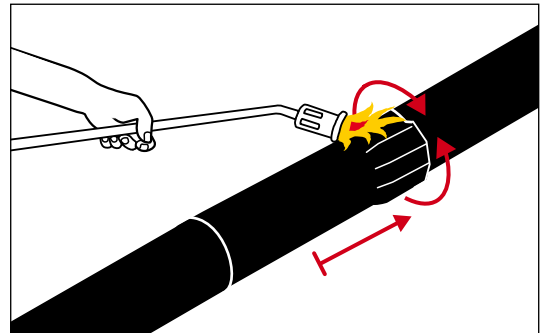
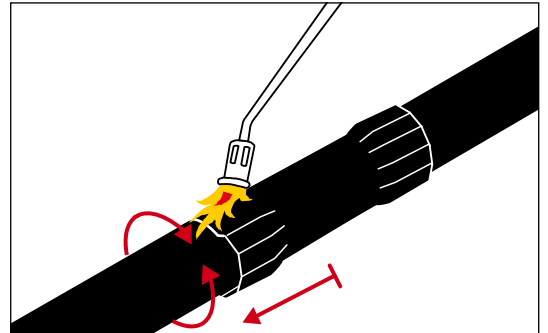

Installing straight joints for SafePipe BXJoints

Shrinkage, *continued*

19. Shrink until all expansion marks have vanished and the end of the sleeve forms an almost straight encircling edge.

- A. Before
- B. After

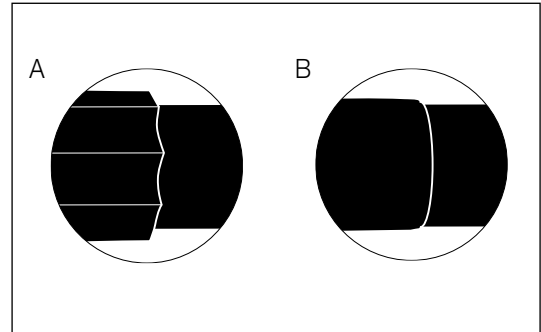

Completed joint

20. The joint is complete.

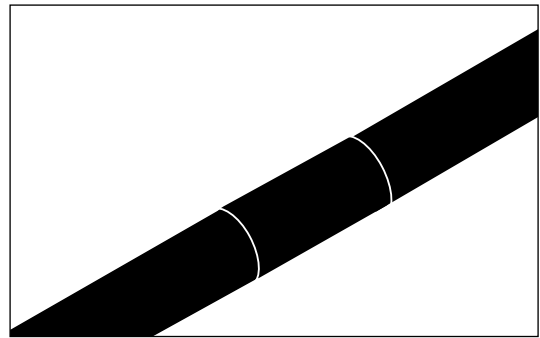

Contact details

Denmark

LOGSTOR Denmark Holding ApS
Danmarksvej 11 | DK-9670 Løgstør

T: +45 99 66 10 00
E: logstor@kingspan.com



For the product offering in other markets please contact your local sales representative or visit www.logstor.com

Care has been taken to ensure that the contents of this publication are accurate, but Kingspan Limited and its subsidiary companies do not accept responsibility for errors or for information that is found to be misleading. Suggestions for, or description of, the end use or application of products or methods of working are for information only and Kingspan Limited and its subsidiaries accept no liability in respect thereof.

To ensure you are viewing the most recent and accurate product information, please scan the QR code directly above.

